

Jumping Jack Flash 2

This target can display up to three standard cardboard targets. One is stationary, one pops up from behind, and one pops up in front. Depending on which are shoot targets, which are no-shoot targets, and the relative height of each, several easy to very difficult shooting scenarios can be made.

The two targets that pop up have variable speed capability.

They may independently be set for immediate pop up or may come up very slowly, taking over 10 seconds to rise.

Standard screen door closer cylinders are used to power this target. They provide the spring power to raise the targets, and they also provide the variable rise times by adjusting their air bleed screws.

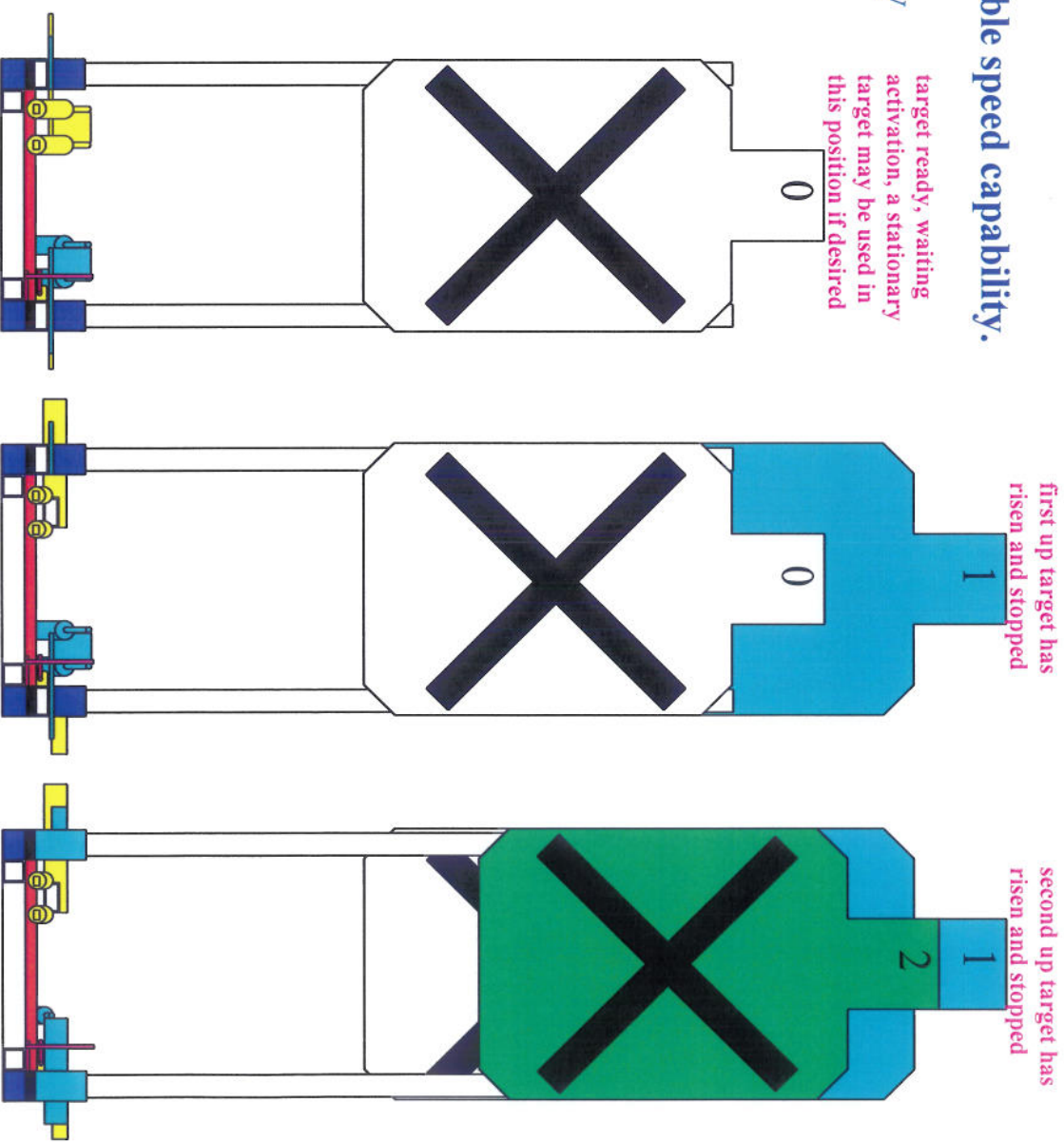

Jumping Jack Flash 2

How It Works

side view:
First Up Section Only
Condition = Ready:

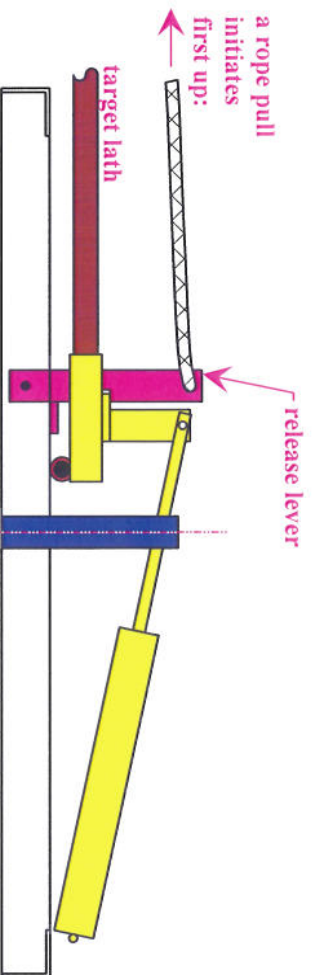

side view:
First Up Section Only
Condition = Activated and Rising:

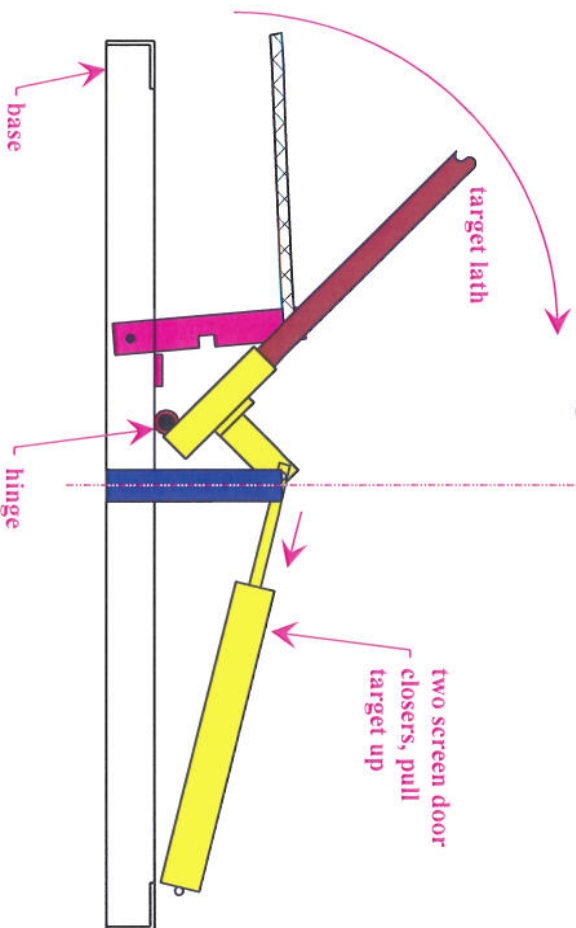

top view
after all
movement
has stopped

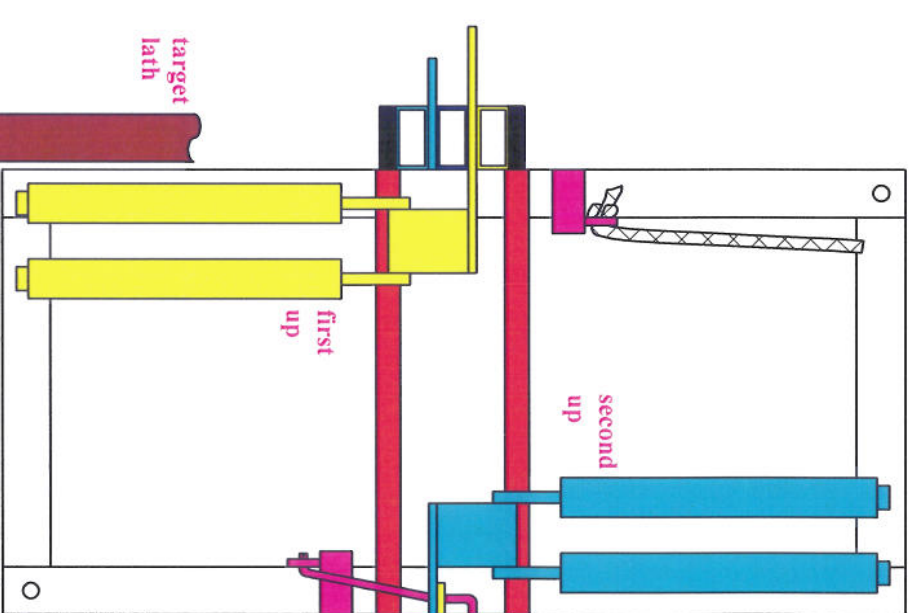

step here
to reset
second up

step here
to reset
first up

front view
after all
movement
has stopped

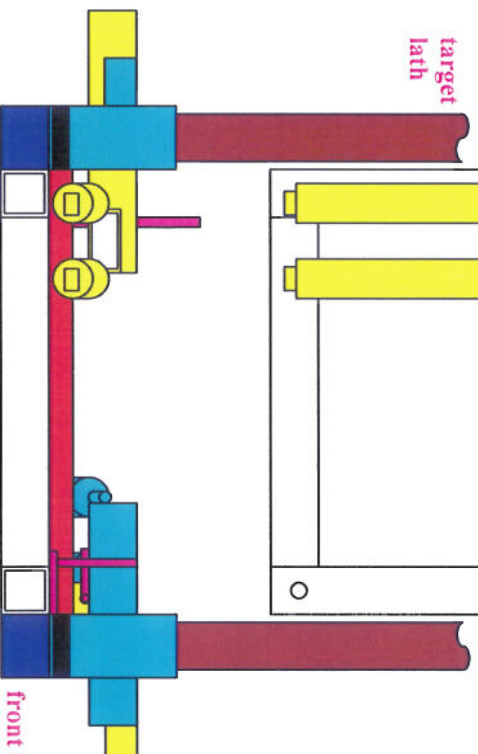

Jumping Jack Flash 2

Lath Holders

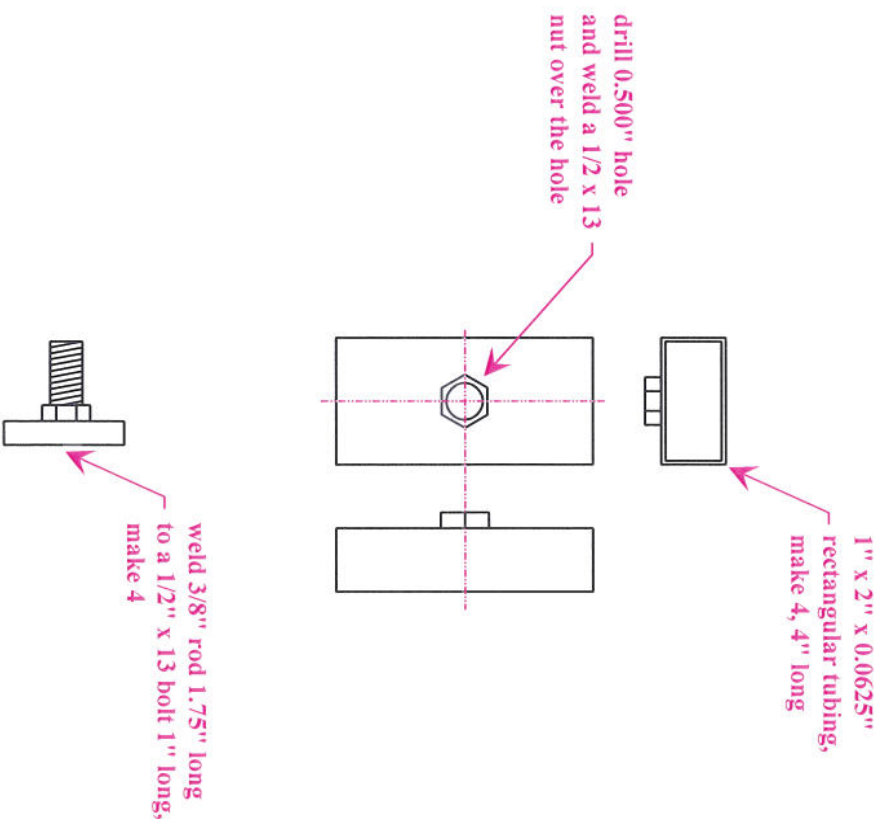
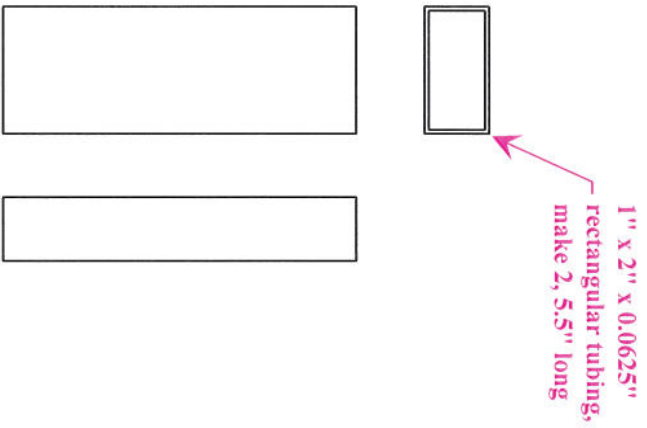

Jumping Jack Flash 2

Base Assembly. make one.

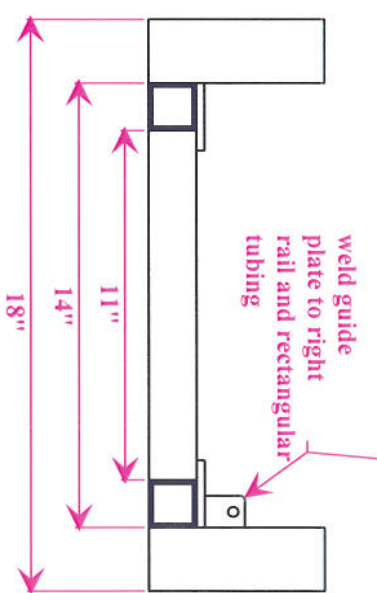
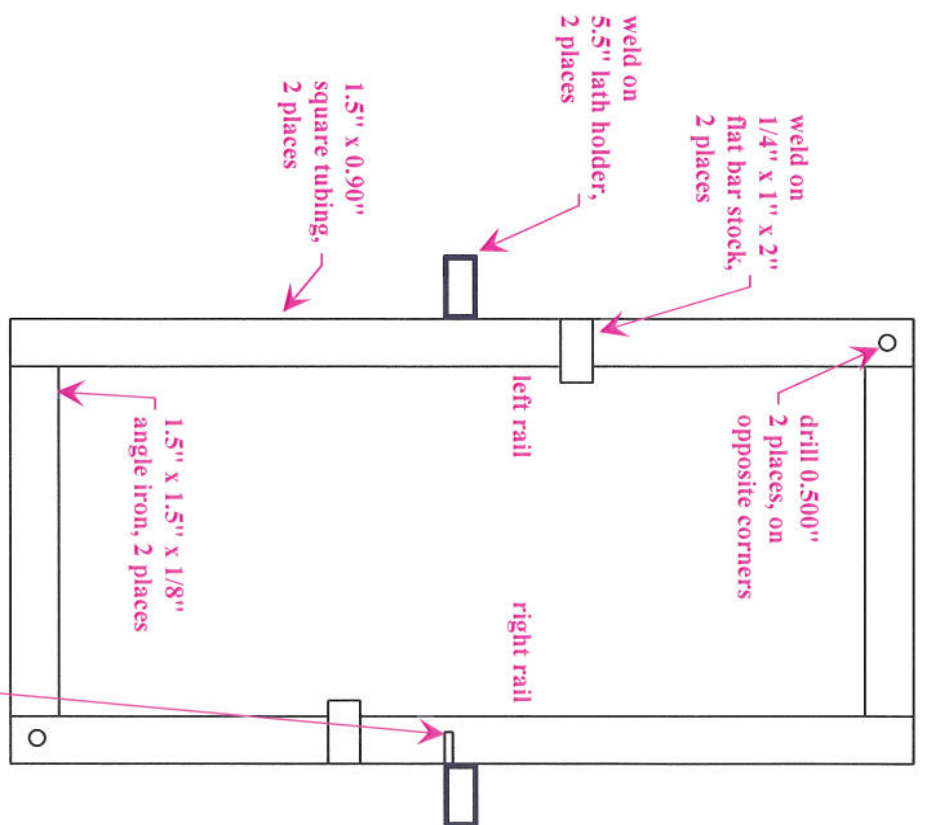
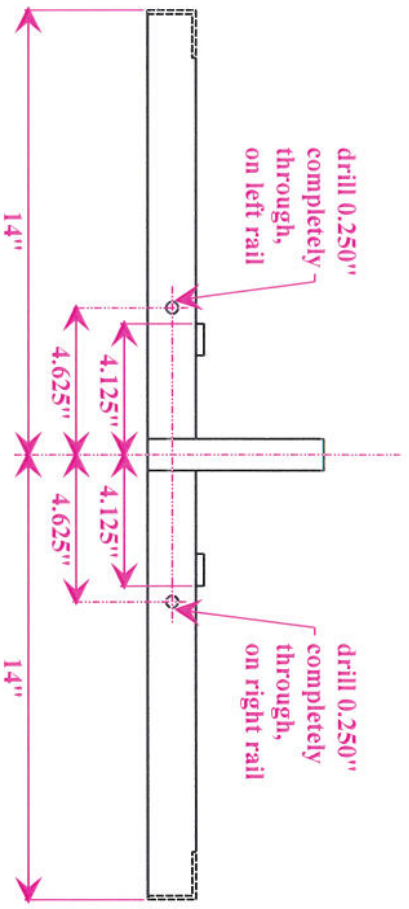
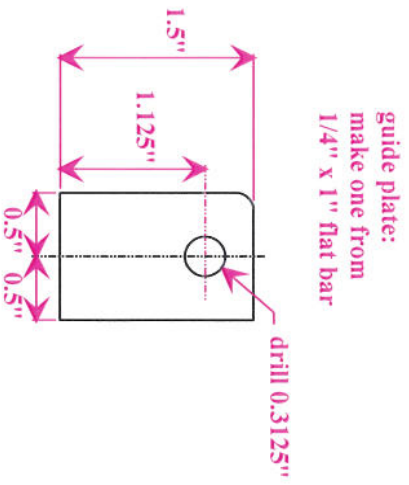

Jumping Jack Flash 2

First Up Assembly, make one

weld 4" lath holder
to 1/2" round bar,
2 places

1/2" round bar turning
within the 1/2" black pipe
forms the hinge and must
rotate freely

1/2" black pipe

1" x 2" x 0.0625"
rectangular tubing,
2.5" long

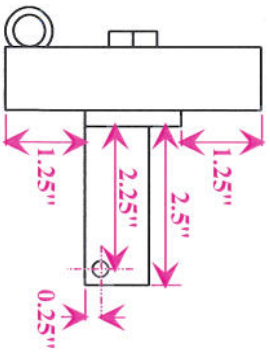

Jumping Jack Flash 2

Second Up Assembly. make one

weld 4" lath holder
to 1/2" round bar,
2 places

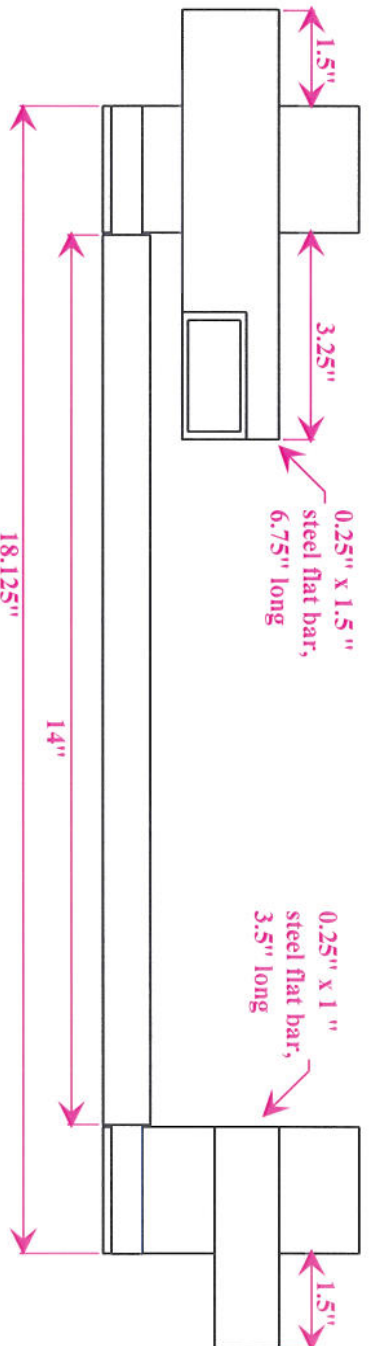
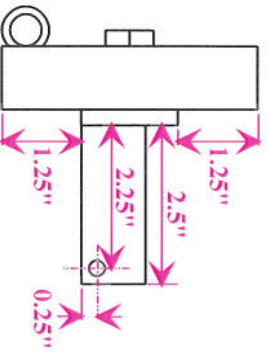
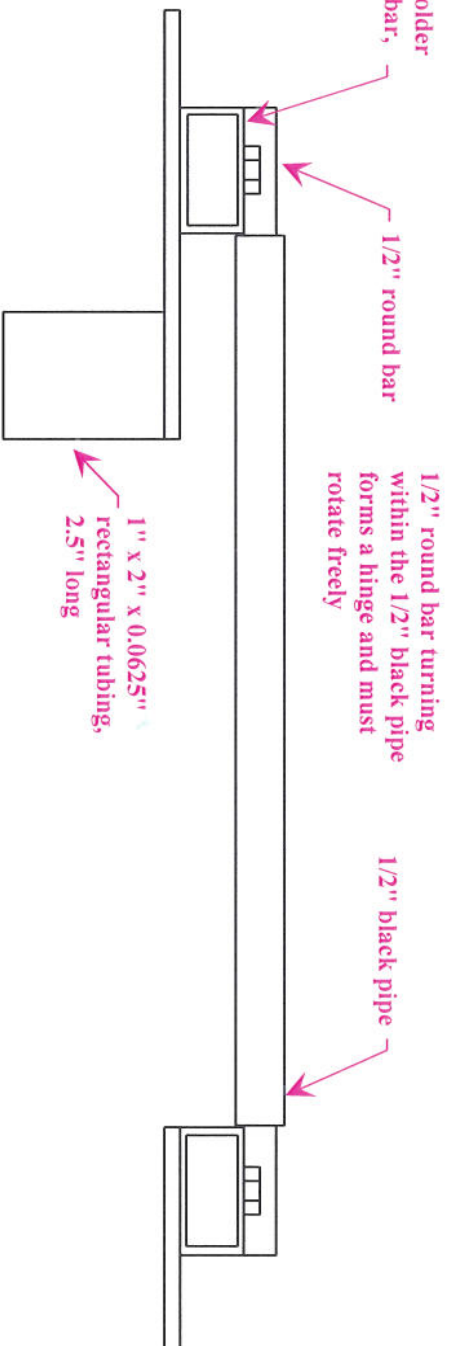

Jumping Jack Flash 2

Base Assembly. make from

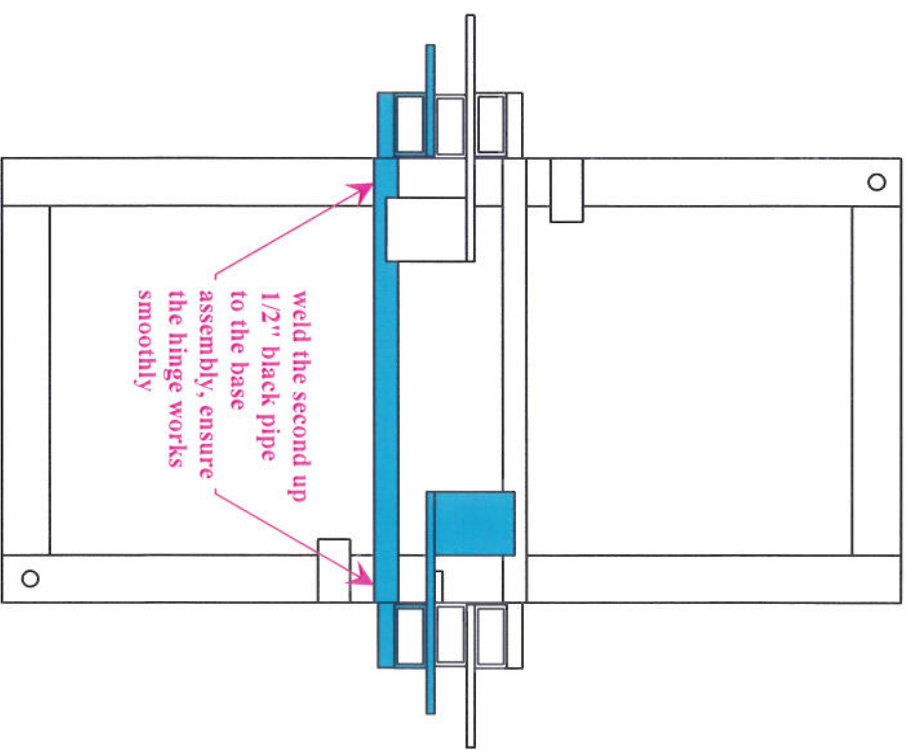
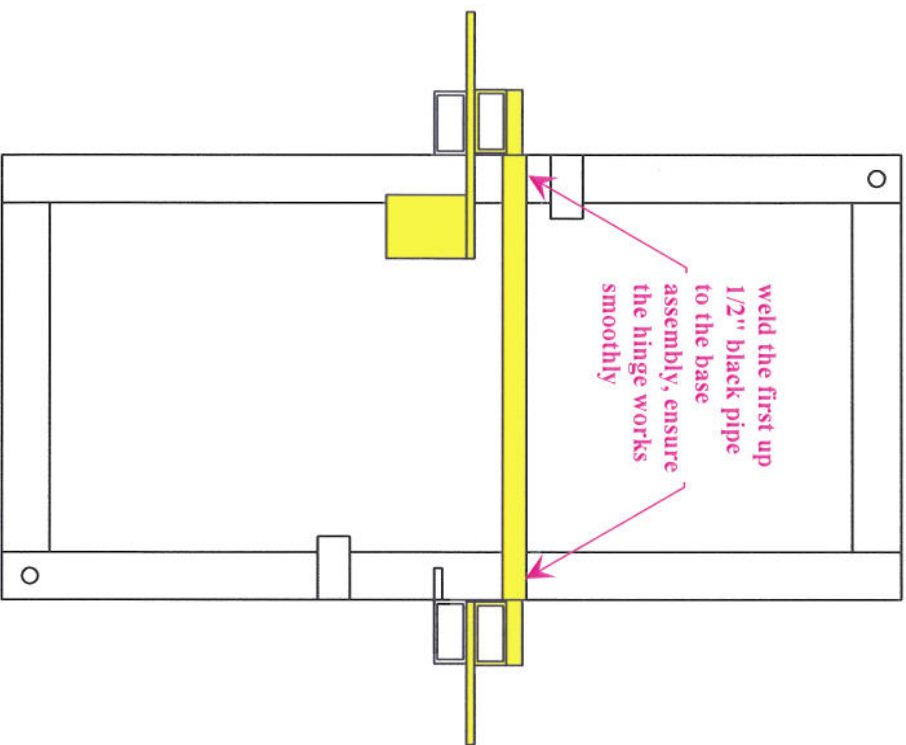

Jumping Jack Flash 2

Release Lever, make one first up release and one second up release

first up release lever

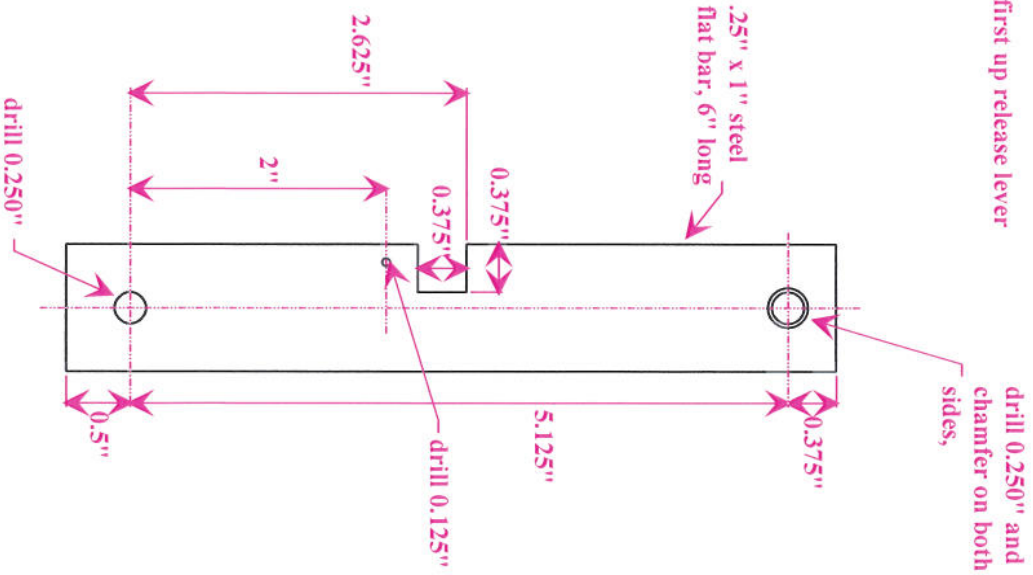

second up release lever

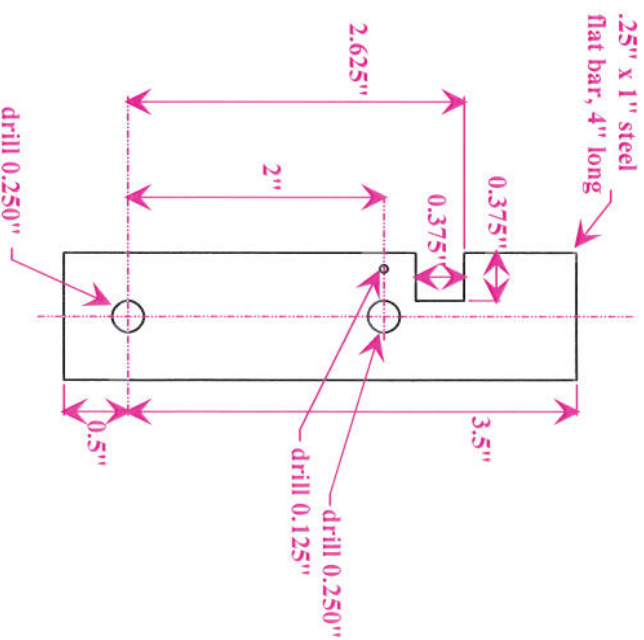

Jumping Jack Flash 2

Second Up Release Rod, make one from 1/4" steel round rod

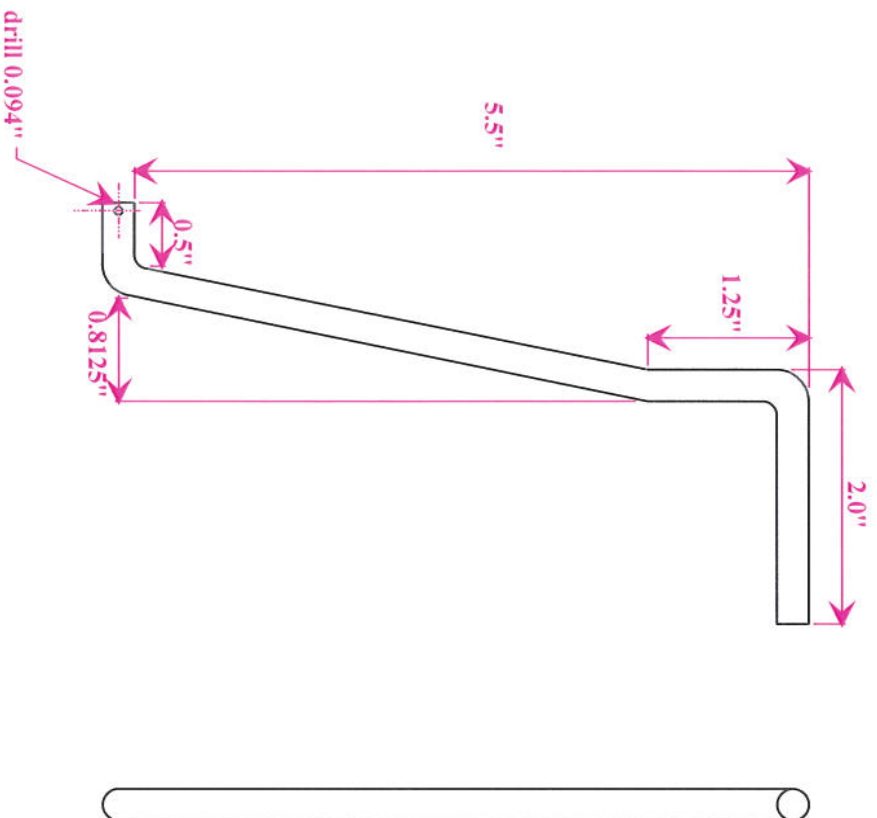

Jumping Jack Flash 2

Final Assembly, attach screen door closers
release arms, and release rod.

