

Welding Cart Addition

- 1 40"x29.5"x1/16" sheet steel -drawer
- 6' 1 1/4"x1/4" angle -front uprights
- 8' 1 1/2"x1/4" hot rolled bar -rear loop
- 6' 1 1/2"x1/4" hot rolled bar -top horizontal
- 20" 3"x1/4" hot rolled bar -front caster mount
- 60" 3 1/2"x3/16" hot rolled bar -cable winder sides
- 20" 1/2" tool steel round rod -rear axle
- 14" 1 1/2" od round tubing -handle
- 1 13 1/4" x 22" x 1/2" plywood -top shelf
- 28" 1 1/2" x 1/8" angle iron -top shelf cross braces
- 14" 2" x 1/8" bar stock -top shelf cross brace
- 2" 10" od round tube -cable winder curve
- 2 4" swivel casters -front wheels
- 2 10" wheels -rear wheels
- 1 drawer pull -drawer
- 2 black rustoleum spray paint

drawer 21" long x 9.5" high x 10.5" wide
bend from 16ga steel, weld corners

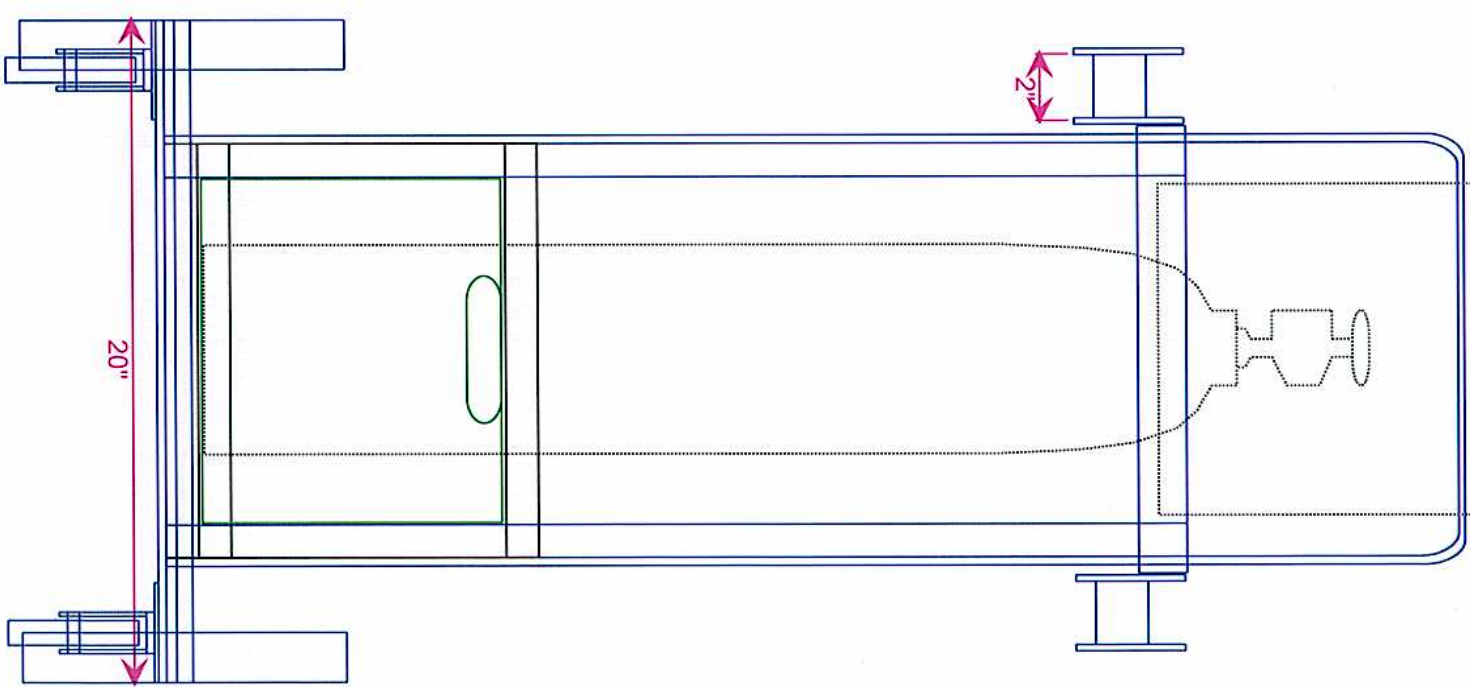
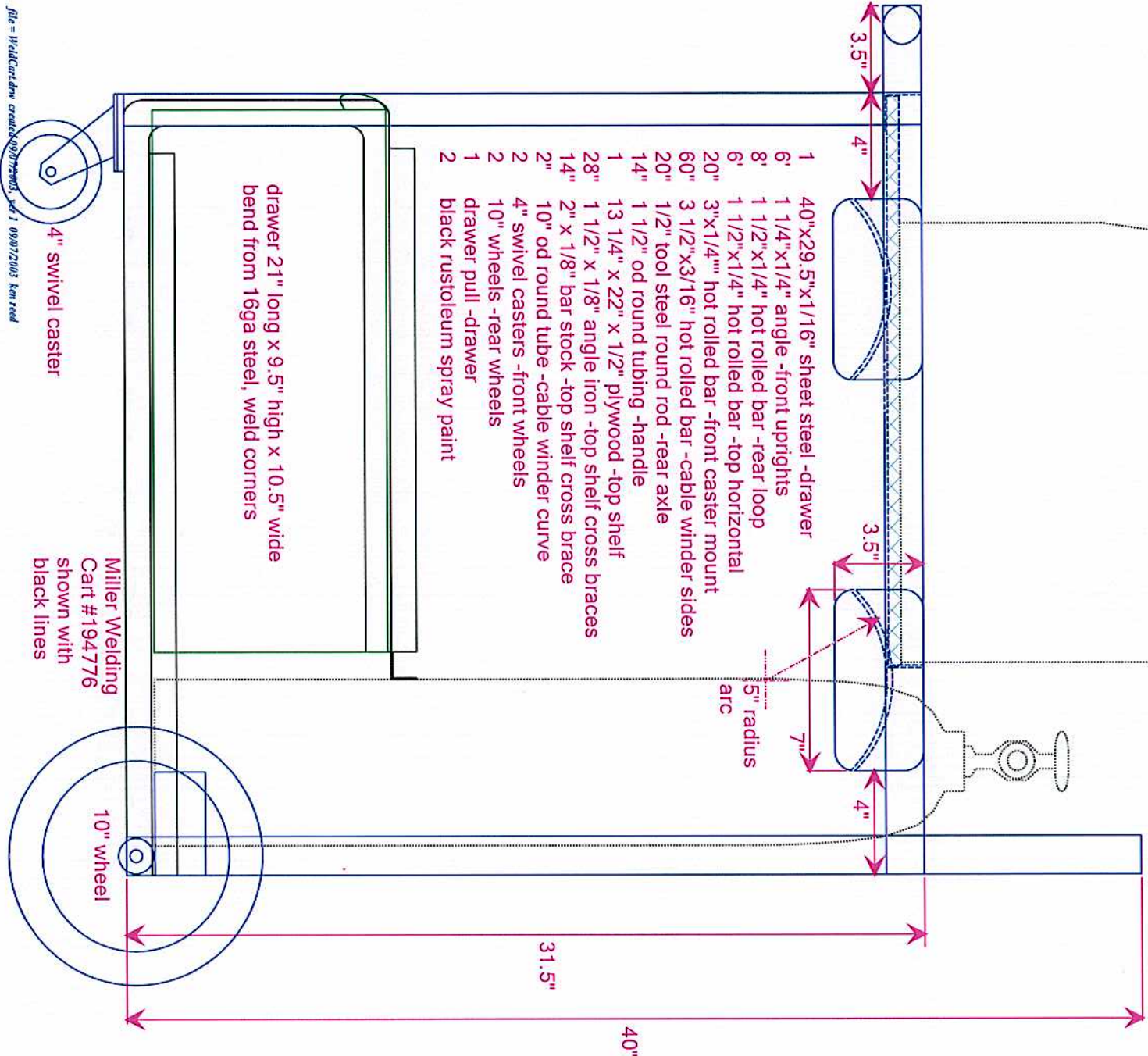

4" swivel caster
Miller Welding
Cart #194776
shown with
black lines

Welding Cart Original

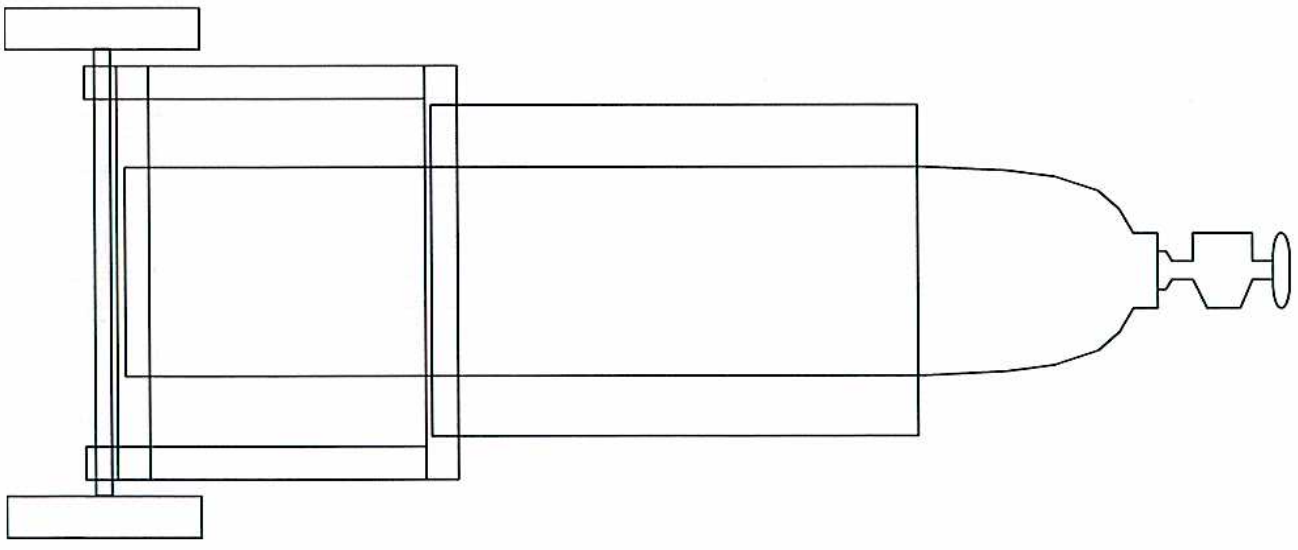
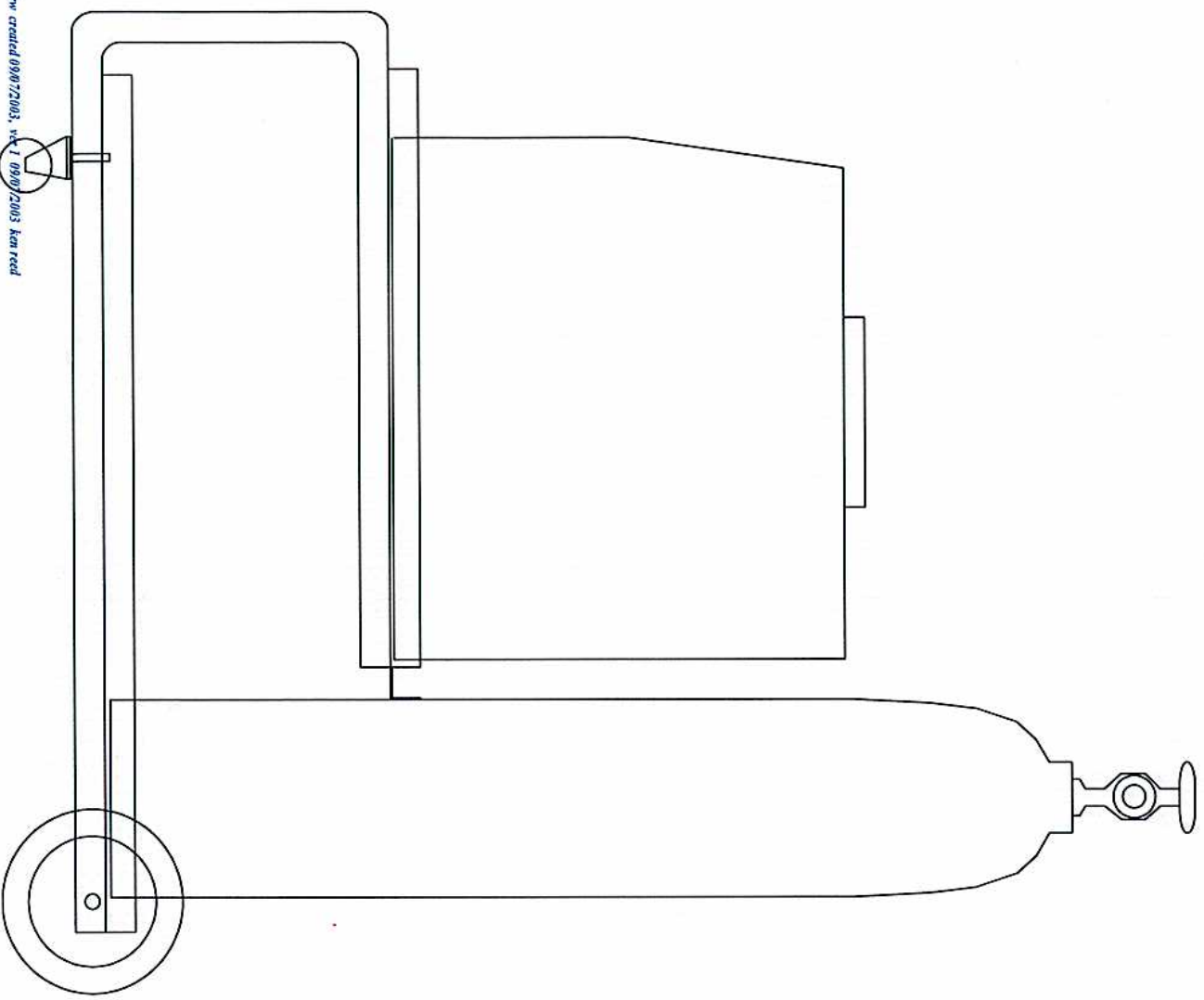

Welding Cart Addition

Drawer Cutting Detail

Make 1 from 0.062" steel

